

## IMPORTANT NOTES

One of HexaLug's greatest features is caliber differentiation. HexaLug devices made for a larger caliber fit smaller caliber muzzle devices, but not vice versa.

Originally, this was achieved through different length muzzle devices. Muzzle devices for 7.62 mm are 6 mm longer than those for 5.56 mm.

When we only made suppressors with integral HexaLug interfaces, we had control over the location of the first baffle. The first baffle was located close to the tip of the muzzle device, so that a 5.56 mm suppressor did not fit a 7.62 mm muzzle device.

The changeover to interchangeable "HUB" interfaces requires more room in the suppressor for longer mounting systems and we do not have control over the design of suppressors made by other manufacturers.

Therefore, we decided to refine and adapt the HexaLug design. Instead of integrating a caliber specific end stop into our HexaLug HUB adapters, we changed the caliber differentiation from length to diameter. This resulted in an updated design of the 5.56 mm muzzle devices. No changes were made to 7.62 mm muzzle devices.

## COMPATIBILITY

Older suppressors are fully compatible with Gen. 2 muzzle devices.

New suppressors with integral HexaLug interfaces will remain compatible with Gen. 1 muzzle devices.

5.56 mm HUB adapters require Gen. 2 muzzle devices. If you bought a 5.56 mm HUB adapter, we will replace your Gen. 1 muzzle devices at a massively reduced price. Please contact us at [info@acheron.ch](mailto:info@acheron.ch).

Gen. 1

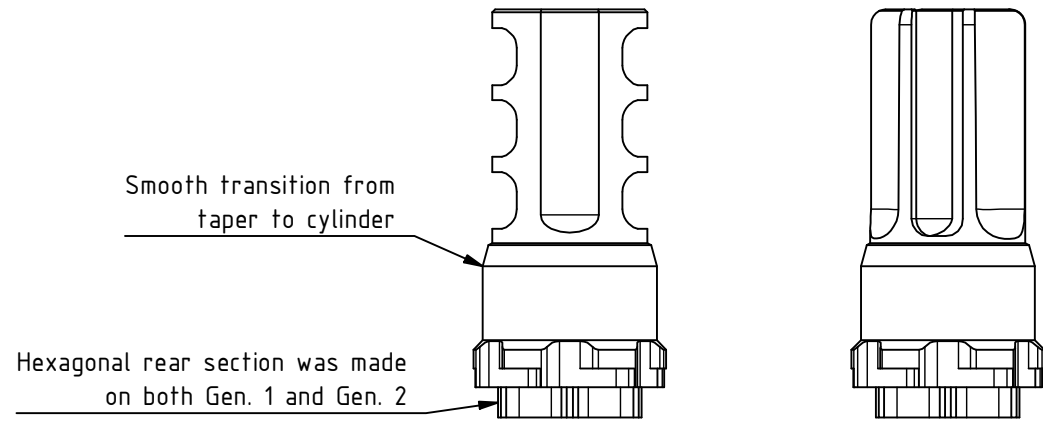

Gen. 2

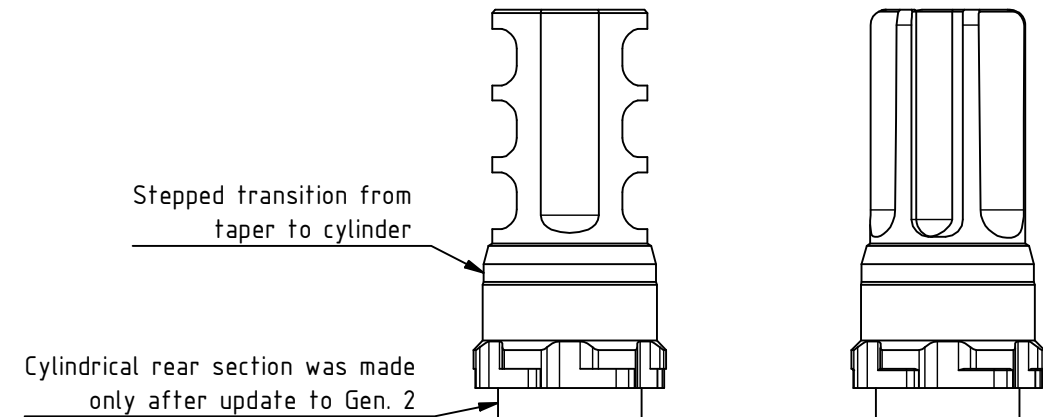

|   |              |            |                                      |                                    |                            |       |        |              |
|---|--------------|------------|--------------------------------------|------------------------------------|----------------------------|-------|--------|--------------|
| Created   | R. Demarmels | 04.09.2025 | Material                             | Weight                             | Surface Treatment & Finish |       |        |              |
| Checked   | S. Wetter    | 04.09.2025 | Standard Tolerances<br>ISO 2768 - mK | Document Type<br>Reference Drawing | Scale                      | Sheet | Format | Units        |
| Approved  | R. Demarmels | 04.09.2025 |                                      |                                    | 1 : 1                      | 1/1   | A4     | mm / deg / g |
| <small>This document is intended for the internal use of recipients only and may not be distributed externally or reproduced for external distribution in any form without express written permission of Acheron AG, Switzerland.</small> |              |            | Designation                          | Drawing Number                     |                            | Index |        |              |
|   |              |            | HexaLug Gen. 2 Muzzle Devices        |                                    | 115003059                  |       |        |              |